

# CERTIFICATE

Certified Passive House Component

Component-ID 1894ws03 valid until 31st Decembar 2023

Passive House Institute  
Dr. Wolfgang Feist  
64283 Darmstadt  
Germany

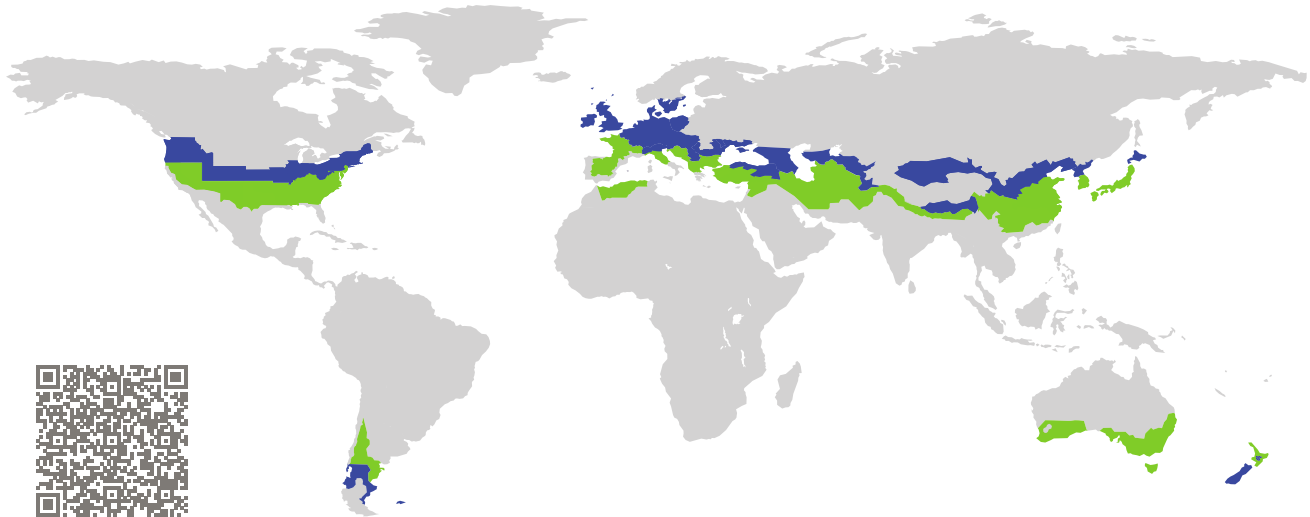

Category: **Window system**  
Manufacturer: **pro Passivhausfenster GmbH,  
Oberaudorf,  
Germany**  
Product name: **smartwin solar**

**This certificate was awarded based on the following  
criteria for the cool, temperate climate zone**

Comfort  $U_W = 0.78 \leq 0.80 \text{ W}/(\text{m}^2 \cdot \text{K})$   
 $U_{W,\text{installed}}$   $\leq 0.85 \text{ W}/(\text{m}^2 \cdot \text{K})$   
with  $U_g$   $= 0.70 \text{ W}/(\text{m}^2 \cdot \text{K})$

Hygiene  $f_{Rsi=0.25} \geq 0.70$   
Airtightness  $Q_{100} = 0.24 \leq 0.25 \text{ m}^3/(\text{h} \cdot \text{m})$

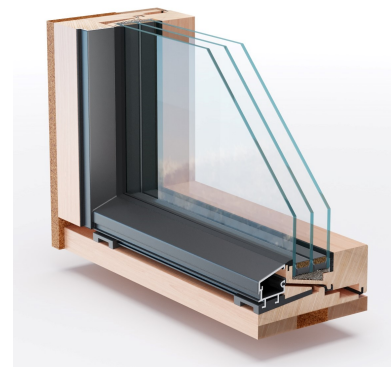

Passive House  
efficiency class

phE

phD

phC

phB

phA

cool, temperate climate



**CERTIFIED  
COMPONENT**

Passive House Institute

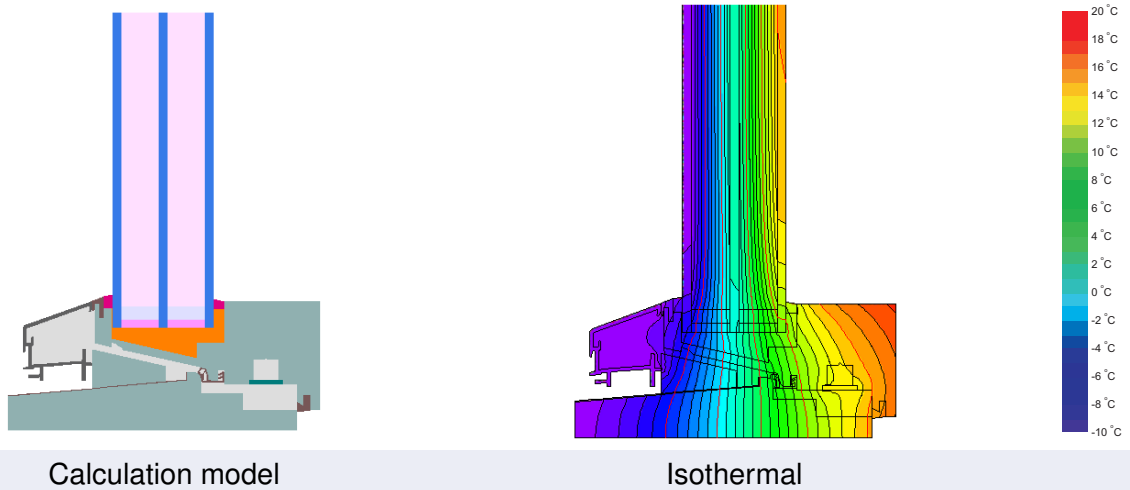

Calculation model Isothermal

## Description

Timber-Aluminum window frame (spruce/fir 0.11 W/(mK) with natural insulation (0.04 W/(mK). Glass loads are carried by special corner pieces. The airtightness test was conducted on a combination of fixed glazing and tilt and turn sash, element size 2.0m \* 2.6m. The window installation will be designed individually by the manufacturer. Pane thickness: 48 mm (4/18/4/18/4), rebate depth: 15 mm. Spacer: SWISSPACER Ultimate.

## Explanation

The window U-values were calculated for the test window size of 2.46 m × 1.48 m with  $U_g = 0.70 \text{ W}/(\text{m}^2 \cdot \text{K})$ . If a higher quality glazing is used, the window U-values will improve as follows:









Glazing	$U_g =$	0.70	0.64	0.58	0.52	W/(m <sup>2</sup> · K)
		↓	↓	↓	↓	
Window	$U_w =$	0.78	0.73	0.68	0.63	W/(m <sup>2</sup> · K)

Transparent building components are classified into efficiency classes depending on the heat losses through the opaque part. The frame U-Values, frame widths, thermal bridges at the glazing edge, and the glazing edge lengths are included in these heat losses. A more detailed report of the calculations performed in the context of certification is available from the manufacturer.

The Passive House Institute has defined international component criteria for seven climate zones. In principle, components which have been certified for climate zones with higher requirements may also be used in climates with less stringent requirements. In a particular climate zone it may make sense to use a component of a higher thermal quality which has been certified for a climate zone with more stringent requirements.

Further information relating to certification can be found on [www.passivehouse.com](http://www.passivehouse.com) and [passipedia.org](http://passipedia.org).

Frame values		Frame width $b_f$ mm	$U$ -value frame $U_f$ W/(m <sup>2</sup> · K)	$\Psi$ -glazing edge $\Psi_g$ W/(m · K)	Temp. Factor $f_{RSi=0.25}$ [-]
Mullion fixed	(0M1)	110	0.69	0.028	0.71
Mullion fixed	(0M2)	110	0.82	0.027	0.69
Transom fixed	(0T1)	110	0.74	0.027	0.70
Transom fixed	(0T2)	110	0.82	0.027	0.69
Mullion 1 casement	(1M1)	80	0.84	0.027	0.71
Mullion 1 casement	(1M2)	110	0.78	0.027	0.71
Mullion 1 casement	(1M3)	80	0.95	0.026	0.70
Mullion 1 casement	(1M4)	110	0.95	0.026	0.69
Transom 1 casement	(1T1)	80	0.83	0.027	0.70
Transom 1 casement	(1T2)	110	0.83	0.028	0.70
Transom 1 casement	(1T3)	80	0.87	0.026	0.70
Transom 1 casement	(1T4)	110	0.90	0.026	0.69
Mullion 2 casements	(2M1)	110	0.75	0.026	0.72
Mullion 2 casements	(2M2)	110	0.90	0.026	0.71
Transom 2 casements	(2T1)	110	0.81	0.026	0.72
Transom 2 casements	(2T2)	124	0.81	0.026	0.71
Transom 2 casements	(2T3)	110	0.87	0.026	0.71
Transom 2 casements	(2T4)	124	0.89	0.026	0.71
Bottom fixed	(FB1)	62	0.68	0.028	0.71
Spacer: MULTITECH G		Secondary seal: Polysulfid			

Frame values		Frame width $b_f$ mm	$U$ -value frame $U_f$ W/(m <sup>2</sup> · K)	$\Psi$ -glazing edge $\Psi_g$ W/(m · K)	Temp. Factor $f_{Rsi=0.25}$ [-]
Top fixed	(FH1) 	62	0.67	0.027	0.72
Lateral fixed	(FJ1) 	62	0.67	0.027	0.72
Flying Mullion	(FM1) 	92	0.76	0.026	0.72
Flying Mullion	(FM2) 	92	0.87	0.026	0.71
Bottom	(OB1) 	62	0.84	0.026	0.71
Top	(OH1) 	62	0.77	0.026	0.72
Lateral	(OJ1) 	62	0.77	0.026	0.72
Threshold	(OT1) 	67	0.91	0.027	0.70

Spacer: MULTITECH G                      Secondary seal: Polysulfid

 Mullion fixed

$b_f = 110 \text{ mm}$   
 $U_f = 0.69 \text{ W/(m}^2 \cdot \text{K)}$   
 $\Psi_g = 0.028 \text{ W/(m} \cdot \text{K)}$   
 $f_{Rsi} = 0.71$

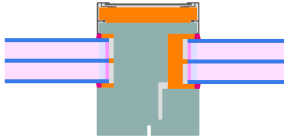
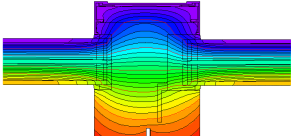
 Mullion fixed

$b_f = 110 \text{ mm}$   
 $U_f = 0.82 \text{ W/(m}^2 \cdot \text{K)}$   
 $\Psi_g = 0.027 \text{ W/(m} \cdot \text{K)}$   
 $f_{Rsi} = 0.69$

 Transom fixed

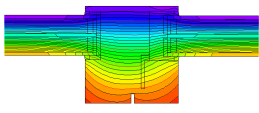
$b_f = 110 \text{ mm}$   
 $U_f = 0.74 \text{ W/(m}^2 \cdot \text{K)}$   
 $\Psi_g = 0.027 \text{ W/(m} \cdot \text{K)}$   
 $f_{Rsi} = 0.70$

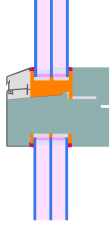
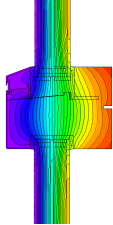

**Transom**  
fixed

$$b_f = 110 \text{ mm}$$

$$U_f = 0.82 \text{ W}/(\text{m}^2 \cdot \text{K})$$

$$\Psi_g = 0.027 \text{ W}/(\text{m} \cdot \text{K})$$

$$f_{Rsi} = 0.69$$

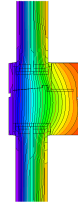

**Mullion**  
1 casement

$$b_f = 80 \text{ mm}$$

$$U_f = 0.84 \text{ W}/(\text{m}^2 \cdot \text{K})$$

$$\Psi_g = 0.027 \text{ W}/(\text{m} \cdot \text{K})$$

$$f_{Rsi} = 0.71$$

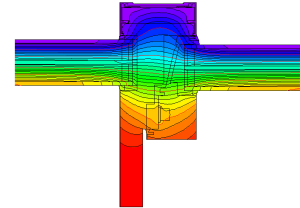
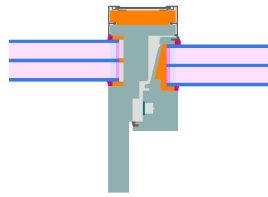

**Mullion**  
1 casement

$$b_f = 110 \text{ mm}$$

$$U_f = 0.78 \text{ W}/(\text{m}^2 \cdot \text{K})$$

$$\Psi_g = 0.027 \text{ W}/(\text{m} \cdot \text{K})$$

$$f_{Rsi} = 0.71$$

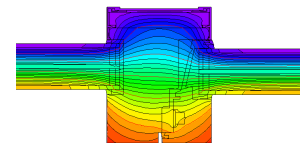
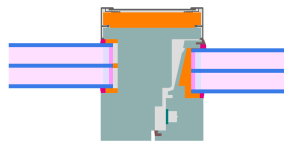

**Mullion**  
1 casement

$$b_f = 80 \text{ mm}$$

$$U_f = 0.95 \text{ W}/(\text{m}^2 \cdot \text{K})$$

$$\Psi_g = 0.026 \text{ W}/(\text{m} \cdot \text{K})$$

$$f_{Rsi} = 0.70$$

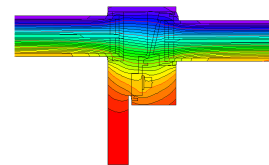
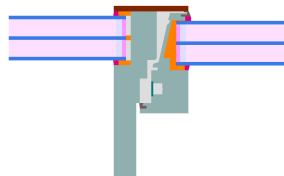

**Mullion**  
1 casement

$$b_f = 110 \text{ mm}$$

$$U_f = 0.95 \text{ W}/(\text{m}^2 \cdot \text{K})$$

$$\Psi_g = 0.026 \text{ W}/(\text{m} \cdot \text{K})$$

$$f_{Rsi} = 0.69$$

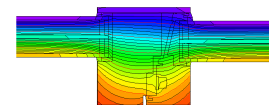
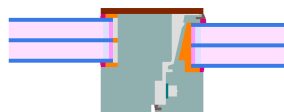



**Transom**  
1 casement

$$b_f = 80 \text{ mm}$$
$$U_f = 0.83 \text{ W}/(\text{m}^2 \cdot \text{K})$$
$$\Psi_g = 0.027 \text{ W}/(\text{m} \cdot \text{K})$$
$$f_{Rsi} = 0.70$$

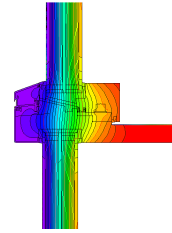
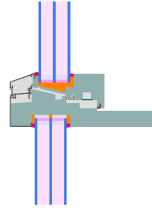

**Transom**  
1 casement

$$b_f = 110 \text{ mm}$$
$$U_f = 0.83 \text{ W}/(\text{m}^2 \cdot \text{K})$$
$$\Psi_g = 0.028 \text{ W}/(\text{m} \cdot \text{K})$$
$$f_{Rsi} = 0.70$$

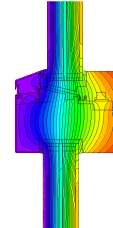
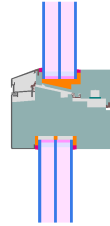

**Transom**  
1 casement

$$b_f = 80 \text{ mm}$$
$$U_f = 0.87 \text{ W}/(\text{m}^2 \cdot \text{K})$$
$$\Psi_g = 0.026 \text{ W}/(\text{m} \cdot \text{K})$$
$$f_{Rsi} = 0.70$$

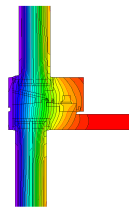
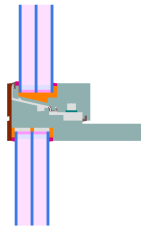

**Transom**  
1 casement

$$b_f = 110 \text{ mm}$$
$$U_f = 0.90 \text{ W}/(\text{m}^2 \cdot \text{K})$$
$$\Psi_g = 0.026 \text{ W}/(\text{m} \cdot \text{K})$$
$$f_{Rsi} = 0.69$$

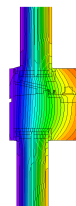

**Mullion**  
2 casements

$$b_f = 110 \text{ mm}$$
$$U_f = 0.75 \text{ W}/(\text{m}^2 \cdot \text{K})$$
$$\Psi_g = 0.026 \text{ W}/(\text{m} \cdot \text{K})$$
$$f_{Rsi} = 0.72$$

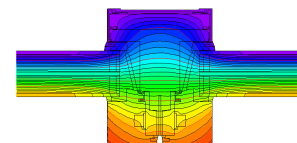
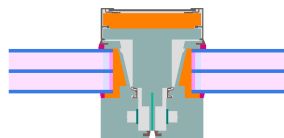



**Mullion**  
2 casements

$$b_f = 110 \text{ mm}$$
$$U_f = 0.90 \text{ W}/(\text{m}^2 \cdot \text{K})$$
$$\Psi_g = 0.026 \text{ W}/(\text{m} \cdot \text{K})$$
$$f_{Rsi} = 0.71$$

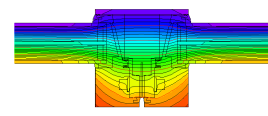
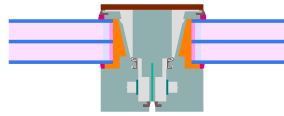

**Transom**  
2 casements

$$b_f = 110 \text{ mm}$$
$$U_f = 0.81 \text{ W}/(\text{m}^2 \cdot \text{K})$$
$$\Psi_g = 0.026 \text{ W}/(\text{m} \cdot \text{K})$$
$$f_{Rsi} = 0.72$$

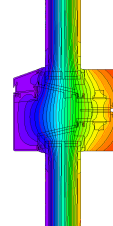
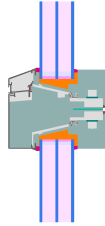

**Transom**  
2 casements

$$b_f = 124 \text{ mm}$$
$$U_f = 0.81 \text{ W}/(\text{m}^2 \cdot \text{K})$$
$$\Psi_g = 0.026 \text{ W}/(\text{m} \cdot \text{K})$$
$$f_{Rsi} = 0.71$$

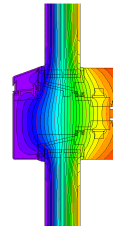
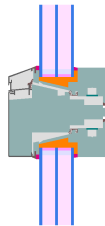

**Transom**  
2 casements

$$b_f = 110 \text{ mm}$$
$$U_f = 0.87 \text{ W}/(\text{m}^2 \cdot \text{K})$$
$$\Psi_g = 0.026 \text{ W}/(\text{m} \cdot \text{K})$$
$$f_{Rsi} = 0.71$$

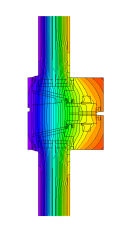
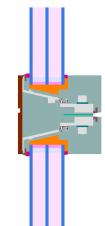

**Transom**  
2 casements

$$b_f = 124 \text{ mm}$$
$$U_f = 0.89 \text{ W}/(\text{m}^2 \cdot \text{K})$$
$$\Psi_g = 0.026 \text{ W}/(\text{m} \cdot \text{K})$$
$$f_{Rsi} = 0.71$$

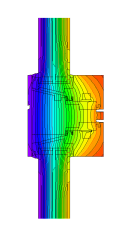



Bottom  
fixed

$$b_f = 62 \text{ mm}$$

$$U_f = 0.68 \text{ W}/(\text{m}^2 \cdot \text{K})$$

$$\Psi_g = 0.028 \text{ W}/(\text{m} \cdot \text{K})$$

$$f_{Rsi} = 0.71$$

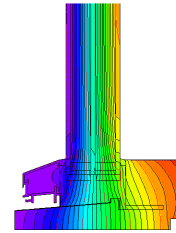
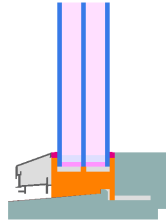

Top  
fixed

$$b_f = 62 \text{ mm}$$

$$U_f = 0.67 \text{ W}/(\text{m}^2 \cdot \text{K})$$

$$\Psi_g = 0.027 \text{ W}/(\text{m} \cdot \text{K})$$

$$f_{Rsi} = 0.72$$

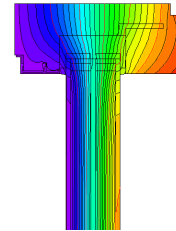
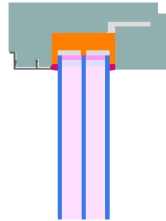

Lateral  
fixed

$$b_f = 62 \text{ mm}$$

$$U_f = 0.67 \text{ W}/(\text{m}^2 \cdot \text{K})$$

$$\Psi_g = 0.027 \text{ W}/(\text{m} \cdot \text{K})$$

$$f_{Rsi} = 0.72$$



Flying Mullion

$$b_f = 92 \text{ mm}$$

$$U_f = 0.76 \text{ W}/(\text{m}^2 \cdot \text{K})$$

$$\Psi_g = 0.026 \text{ W}/(\text{m} \cdot \text{K})$$

$$f_{Rsi} = 0.72$$

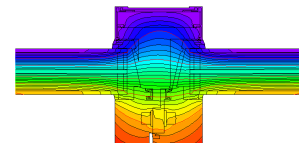
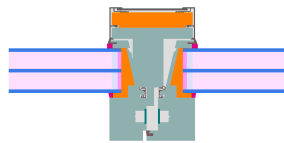

Flying Mullion

$$b_f = 92 \text{ mm}$$

$$U_f = 0.87 \text{ W}/(\text{m}^2 \cdot \text{K})$$

$$\Psi_g = 0.026 \text{ W}/(\text{m} \cdot \text{K})$$

$$f_{Rsi} = 0.71$$

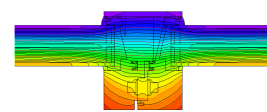
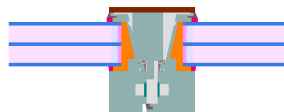





### Bottom

$b_f = 62 \text{ mm}$   
 $U_f = 0.84 \text{ W}/(\text{m}^2 \cdot \text{K})$   
 $\Psi_g = 0.026 \text{ W}/(\text{m} \cdot \text{K})$   
 $f_{Rsi} = 0.71$

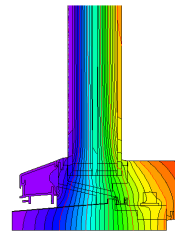
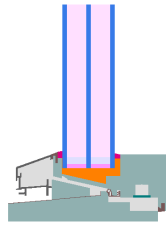

### Top

$b_f = 62 \text{ mm}$   
 $U_f = 0.77 \text{ W}/(\text{m}^2 \cdot \text{K})$   
 $\Psi_g = 0.026 \text{ W}/(\text{m} \cdot \text{K})$   
 $f_{Rsi} = 0.72$

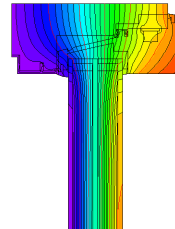
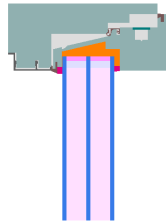

### Lateral

$b_f = 62 \text{ mm}$   
 $U_f = 0.77 \text{ W}/(\text{m}^2 \cdot \text{K})$   
 $\Psi_g = 0.026 \text{ W}/(\text{m} \cdot \text{K})$   
 $f_{Rsi} = 0.72$

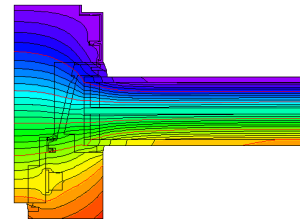
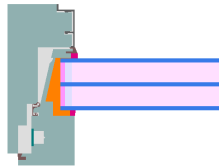

### Threshold

$b_f = 67 \text{ mm}$   
 $U_f = 0.91 \text{ W}/(\text{m}^2 \cdot \text{K})$   
 $\Psi_g = 0.027 \text{ W}/(\text{m} \cdot \text{K})$   
 $f_{Rsi} = 0.70$

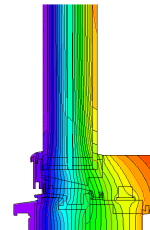
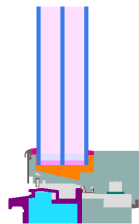

# Validated installations

### Formwork blocks (fixed)

$U_{Wall} = 0.15 \text{ W}/(\text{m}^2 \cdot \text{K})$

Exterior plaster 1.0 W/(mK)  
EPS 0.035 W/(mK)  
Concrete 2.3 W/(mK)  
EPS 0.035 W/(mK)  
Interior plaster 0.57 W/(mK)

Insulation 0.040 W/(mK)

$\Psi_{install}$	W/(m · K)
Top	0.013
Left	0.013
Right	0.013
Bottom	0.024

$U_{W,installed} = 0.82 \text{ W}/(\text{m}^2 \cdot \text{K})$

### Formwork blocks (operable)

$U_{Wall} = 0.15 \text{ W}/(\text{m}^2 \cdot \text{K})$

Exterior plaster 1.0 W/(mK)  
EPS 0.035 W/(mK)  
Concrete 2.3 W/(mK)  
EPS 0.035 W/(mK)  
Interior plaster 0.57 W/(mK)

Insulation 0.040 W/(mK)

$\Psi_{install}$	W/(m · K)
Top	0.013
Left	0.013
Right	0.013
Bottom	0.026

$U_{W,installed} = 0.82 \text{ W}/(\text{m}^2 \cdot \text{K})$

### Lightweight timber (fixed glazed)

$U_{Wall} = 0.13 \text{ W}/(\text{m}^2 \cdot \text{K})$

Exterior plaster 1.0 W/(mK)  
Wood fibre board 0.050 W/(mK)  
Cellulose 0.040 W/(mK)  
OSB-board 0.13 W/(mK)  
Insulation 0.040 W/(mK)  
Plasterboard 0.25 W/(mK)

Insulation 0.040 W/(mK)

$\Psi_{install}$	W/(m · K)
Top	0.015
Left	0.015
Right	0.015
Bottom	0.018

$U_{W,installed} = 0.82 \text{ W}/(\text{m}^2 \cdot \text{K})$

### Lightweight timber (operable)

$U_{Wall} = 0.13 \text{ W}/(\text{m}^2 \cdot \text{K})$

Exterior plaster 1.0 W/(mK)  
Wood fibre board 0.050 W/(mK)  
Cellulose 0.040 W/(mK)  
OSB-board 0.13 W/(mK)  
Insulation 0.040 W/(mK)  
Plasterboard 0.25 W/(mK)

Insulation 0.040 W/(mK)

$\Psi_{install}$	W/(m · K)
Top	0.015
Left	0.015
Right	0.015
Bottom	0.020

$U_{W,installed} = 0.82 \text{ W}/(\text{m}^2 \cdot \text{K})$

### Exterior insulation and finishing system (EIFS) (fixed glazed)

$U_{Wall} = 0.13 \text{ W}/(\text{m}^2 \cdot \text{K})$

Exterior plaster 1.0 W/(mK)  
EPS 0.035 W/(mK)  
Adhesive 0.70 W/(mK)  
Sand-lime brick 1.0 W/(mK)  
Interior plaster 0.57 W/(mK)

Insulation 0.040 W/(mK)

$\Psi_{install}$	W/(m · K)
Top	0.017
Left	0.017
Right	0.017
Bottom	0.019

$U_{W,installed} = 0.82 \text{ W}/(\text{m}^2 \cdot \text{K})$

### Exterior insulation and finishing system (EIFS) (operable)

$U_{Wall} = 0.13 \text{ W}/(\text{m}^2 \cdot \text{K})$

Exterior plaster 1.0 W/(mK)  
EPS 0.035 W/(mK)  
Adhesive 0.70 W/(mK)  
Sand-lime brick 1.0 W/(mK)  
Interior plaster 0.57 W/(mK)

Insulation 0.040 W/(mK)

$\Psi_{install}$	W/(m · K)
Top	0.018
Left	0.018
Right	0.018
Bottom	0.022

$U_{W,installed} = 0.83 \text{ W}/(\text{m}^2 \cdot \text{K})$

Exterior insulation and finishing s (EIFS)  
threshold (operable)

$$U_1 = 0.13 \text{ [W/(m}^2 \cdot \text{K)]}$$

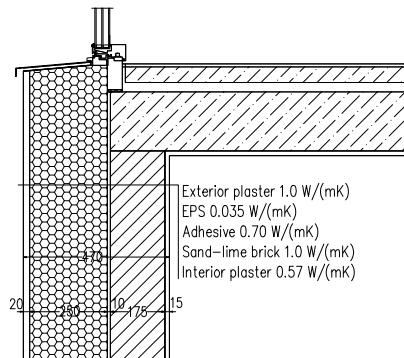

$$\psi_{\text{install}} = 0.03 \text{ W/(m} \cdot \text{K)}$$

